

LMV931 Single/LMV932 Dual/LMV934 Quad 1.8V, RRIO Operational Amplifiers

General Description

The LMV931/LMV932/LMV934 are low voltage, low power operational amplifiers. LMV931/LMV932/LMV934 are guaranteed to operate from +1.8V to +5.5V supply voltages and have rail-to-rail input and output. LMV931/LMV932/LMV934 input common mode voltage extends 200mV beyond the supplies which enables user enhanced functionality beyond the supply voltage range. The output can swing rail-to-rail unloaded and within 105mV from the rail with 600Ω load at 1.8V supply. The LMV931/LMV932/LMV934 are optimized to work at 1.8V which make them ideal for portable two-cell battery powered systems and single cell Li-Ion systems.

LMV931/LMV932/LMV934 exhibit excellent speed-power ratio, achieving 1.4MHz gain bandwidth product at 1.8V supply voltage with very low supply current. The LMV931/LMV932/LMV934 are capable of driving a 600Ω load and up to 1000pF capacitive load with minimal ringing. LMV931/LMV932/LMV934 have a high DC gain of 101dB, making them suitable for low frequency applications.

The single LMV931 is offered in space saving 5-Pin SC70 and SOT23 packages. The dual LMV932 are in 8-Pin MSOP and SOIC packages and the quad LMV934 are in 14-Pin TSSOP and SOIC packages. These small packages are ideal solutions for area constrained PC boards and portable electronics such as cellular phones and PDAs.

Features

(Typical 1.8V Supply Values; Unless Otherwise Noted)

- Guaranteed 1.8V, 2.7V and 5V specifications
- Output swing
 - w/600Ω load 80mV from rail
 - w/2kΩ load 30mV from rail
- V_{CM} 200mV beyond rails
- Supply current (per channel) 100μA
- Gain bandwidth product 1.4MHz
- Maximum V_{OS} 4.0mV
- Ultra tiny packages
- Temperature range -40°C to 125°C

Applications

- Consumer communication
- Consumer computing
- PDAs
- Audio pre-amp
- Portable/battery-powered electronic equipment
- Supply current monitoring
- Battery monitoring

Typical Application

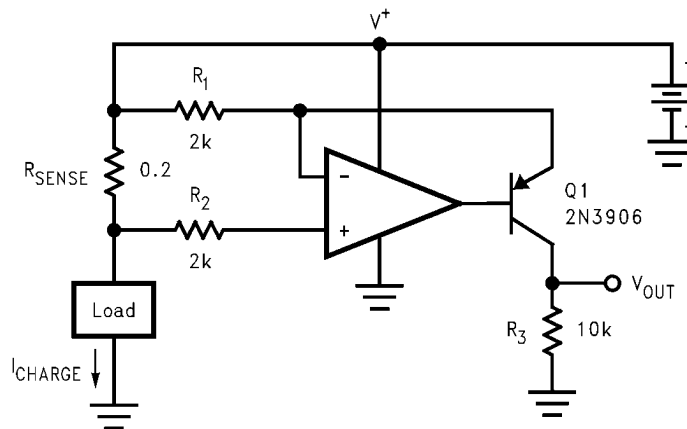

$$V_{OUT} = \frac{R_{SENSE} \cdot R_3}{R_1} \cdot I_{Charge} = 1\Omega \cdot I_{Charge}$$

200326h0

Absolute Maximum Ratings (Note 1)

If Military/Aerospace specified devices are required, please contact the National Semiconductor Sales Office/Distributors for availability and specifications.

ESD Tolerance (Note 2)	
Machine Model	200V
Human Body Model	2000V
Differential Input Voltage	± Supply Voltage
Supply Voltage (V ⁺ -V ⁻)	6V
Output Short Circuit to V ⁺ (Note 3)	
Output Short Circuit to V ⁻ (Note 3)	
Storage Temperature Range	-65°C to 150°C
Junction Temperature (Note 4)	150°C

Mounting Temp.

Infrared or Convection (20 sec)

235°C

Operating Ratings (Note 1)

Supply Voltage Range	1.8V to 5.5V
Temperature Range	-40°C to 125°C
Thermal Resistance (θ _{JA})	
5-Pin SC70	414°C/W
5-Pin SOT23	265°C/W
8-Pin MSOP	235°C/W
8-Pin SOIC	175°C/W
14-Pin TSSOP	155°C/W
14-Pin SOIC	127°C/W

1.8V DC Electrical Characteristics

Unless otherwise specified, all limits guaranteed for T_J = 25°C. V⁺ = 1.8V, V⁻ = 0V, V_{CM} = V⁺/2, V_O = V⁺/2 and R_L > 1 MΩ. **Boldface** limits apply at the temperature extremes. See (Note 10)

Symbol	Parameter	Condition	Min (Note 6)	Typ (Note 5)	Max (Note 6)	Units	
V _{OS}	Input Offset Voltage	LMV931 (Single)		1	4 6	mV	
		LMV932 (Dual) LMV934 (Quad)		1	5.5 7.5	mV	
TCV _{OS}	Input Offset Voltage Average Drift			5.5		µV/°C	
I _B	Input Bias Current			15	35 50	nA	
I _{OS}	Input Offset Current			13	25 40	nA	
I _S	Supply Current (per channel)			103	185 205	µA	
CMRR	Common Mode Rejection Ratio	LMV931, 0 ≤ V _{CM} ≤ 0.6V	60	78		dB	
		1.4V ≤ V _{CM} ≤ 1.8V (Note 8)	55				
		LMV932 and LMV934 0 ≤ V _{CM} ≤ 0.6V	55	76			
		1.4V ≤ V _{CM} ≤ 1.8V (Note 8)	50				
		-0.2V ≤ V _{CM} ≤ 0V	50	72			
		1.8V ≤ V _{CM} ≤ 2.0V					
PSRR	Power Supply Rejection Ratio	1.8V ≤ V ⁺ ≤ 5V	75 70	100		dB	
CMVR	Input Common-Mode Voltage Range	For CMRR Range ≥ 50dB	T _A = 25°C	V ⁻ -0.2	-0.2 to 2.1	V ⁺ +0.2	V
			T _A = -40°C to 85°C	V ⁻		V ⁺	
			T _A = 125°C	V ⁻ +0.2		V ⁺ -0.2	
A _V	Large Signal Voltage Gain LMV931 (Single)	R _L = 600Ω to 0.9V, V _O = 0.2V to 1.6V, V _{CM} = 0.5V	77 73	101		dB	
		R _L = 2kΩ to 0.9V, V _O = 0.2V to 1.6V, V _{CM} = 0.5V	80 75	105			
	Large Signal Voltage Gain LMV932 (Dual) LMV934 (Quad)	R _L = 600Ω to 0.9V, V _O = 0.2V to 1.6V, V _{CM} = 0.5V	75 72	90		dB	
		R _L = 2kΩ to 0.9V, V _O = 0.2V to 1.6V, V _{CM} = 0.5V	78 75	100			

Symbol	Parameter	Condition	Min (Note 6)	Typ (Note 5)	Max (Note 6)	Units
V_O	Output Swing	$R_L = 600\Omega$ to 0.9V $V_{IN} = \pm 100mV$	1.65	1.72		V
			1.63	0.077	0.105 0.120	
		$R_L = 2k\Omega$ to 0.9V $V_{IN} = \pm 100mV$	1.75	1.77		
			1.74	0.024	0.035 0.04	
I_O	Output Short Circuit Current	Sourcing, $V_O = 0V$ $V_{IN} = 100mV$	4	8		mA
		Sinking, $V_O = 1.8V$ $V_{IN} = -100mV$	3.3	9		
			7			
			5			

1.8V AC Electrical Characteristics

Unless otherwise specified, all limits guaranteed for $T_J = 25^\circ C$. $V^+ = 1.8V$, $V^- = 0V$, $V_{CM} = V^+/2$, $V_O = V^+/2$ and $R_L > 1 M\Omega$.

Boldface limits apply at the temperature extremes. See (Note 10)

Symbol	Parameter	Conditions	Min (Note 6)	Typ (Note 5)	Max (Note 6)	Units
SR	Slew Rate	(Note 7)		0.35		V/ μs
GBW	Gain-Bandwidth Product			1.4		MHz
Φ_m	Phase Margin			67		deg
G_m	Gain Margin			7		dB
e_n	Input-Referred Voltage Noise	$f = 1kHz$, $V_{CM} = 0.5V$		60		$\frac{nV}{\sqrt{Hz}}$
i_n	Input-Referred Current Noise	$f = 1kHz$		0.06		$\frac{pA}{\sqrt{Hz}}$
THD	Total Harmonic Distortion	$f = 1kHz$, $A_V = +1$ $R_L = 600\Omega$, $V_{IN} = 1 V_{PP}$		0.023		%
	Amp-to-Amp Isolation	(Note 9)		123		dB

2.7V DC Electrical Characteristics

Unless otherwise specified, all limits guaranteed for $T_J = 25^\circ\text{C}$. $V^+ = 2.7\text{V}$, $V^- = 0\text{V}$, $V_{\text{CM}} = V^+/2$, $V_O = V^+/2$ and $R_L > 1\text{M}\Omega$. **Boldface** limits apply at the temperature extremes. See (Note 10)

Symbol	Parameter	Condition	Min (Note 6)	Typ (Note 5)	Max (Note 6)	Units	
V_{OS}	Input Offset Voltage	LMV931 (Single)		1	4 6	mV	
		LMV932 (Dual) LMV934 (Quad)		1	5.5 7.5	mV	
TCV_{OS}	Input Offset Voltage Average Drift			5.5		$\mu\text{V}/^\circ\text{C}$	
I_{B}	Input Bias Current			15	35 50	nA	
I_{OS}	Input Offset Current			8	25 40	nA	
I_{S}	Supply Current (per channel)			105	190 210	μA	
CMRR	Common Mode Rejection Ratio	LMV931, $0 \leq V_{\text{CM}} \leq 1.5\text{V}$ $2.3\text{V} \leq V_{\text{CM}} \leq 2.7\text{V}$ (Note 8)	60 55	81		dB	
		LMV932 and LMV934 $0 \leq V_{\text{CM}} \leq 1.5\text{V}$ $2.3\text{V} \leq V_{\text{CM}} \leq 2.7\text{V}$ (Note 8)	55 50	80			
		$-0.2\text{V} \leq V_{\text{CM}} \leq 0\text{V}$ $2.7\text{V} \leq V_{\text{CM}} \leq 2.9\text{V}$	50	74			
PSRR	Power Supply Rejection Ratio	$1.8\text{V} \leq V^+ \leq 5\text{V}$ $V_{\text{CM}} = 0.5\text{V}$	75 70	100		dB	
V_{CM}	Input Common-Mode Voltage Range	For CMRR Range $\geq 50\text{dB}$	$T_A = 25^\circ\text{C}$	$V^- - 0.2$	-0.2 to 3.0	$V^+ + 0.2$	V
			$T_A = -40^\circ\text{C}$ to 85°C	V^-		V^+	
			$T_A = 125^\circ\text{C}$	$V^- + 0.2$		$V^+ - 0.2$	
A_V	Large Signal Voltage Gain LMV931 (Single)	$R_L = 600\Omega$ to 1.35V , $V_O = 0.2\text{V}$ to 2.5V	87 86	104		dB	
		$R_L = 2\text{k}\Omega$ to 1.35V , $V_O = 0.2\text{V}$ to 2.5V	92 91	110			
	Large Signal Voltage Gain LMV932 (Dual) LMV934 (Quad)	$R_L = 600\Omega$ to 1.35V , $V_O = 0.2\text{V}$ to 2.5V	78 75	90		dB	
		$R_L = 2\text{k}\Omega$ to 1.35V , $V_O = 0.2\text{V}$ to 2.5V	81 78	100			
V_O	Output Swing	$R_L = 600\Omega$ to 1.35V $V_{\text{IN}} = \pm 100\text{mV}$	2.55 2.53	2.62		V	
					0.083		0.110 0.130
		$R_L = 2\text{k}\Omega$ to 1.35V $V_{\text{IN}} = \pm 100\text{mV}$	2.65 2.64	2.675			
					0.025		0.04 0.045
I_{O}	Output Short Circuit Current	Sourcing, $V_O = 0\text{V}$ $V_{\text{IN}} = 100\text{mV}$	20 15	30		mA	
		Sinking, $V_O = 0\text{V}$ $V_{\text{IN}} = -100\text{mV}$	18 12	25			

2.7V AC Electrical Characteristics

Unless otherwise specified, all limits guaranteed for $T_J = 25^\circ\text{C}$. $V^+ = 2.7\text{V}$, $V^- = 0\text{V}$, $V_{\text{CM}} = 1.0\text{V}$, $V_O = 1.35\text{V}$ and $R_L > 1\text{ M}\Omega$.

Boldface limits apply at the temperature extremes. See (Note 10)

Symbol	Parameter	Conditions	Min (Note 6)	Typ (Note 5)	Max (Note 6)	Units
SR	Slew Rate	(Note 7)		0.4		V/ μs
GBW	Gain-Bandwidth Product			1.4		MHz
Φ_m	Phase Margin			70		deg
G_m	Gain Margin			7.5		dB
e_n	Input-Referred Voltage Noise	$f = 1\text{kHz}$, $V_{\text{CM}} = 0.5\text{V}$		57		$\frac{\text{nV}}{\sqrt{\text{Hz}}}$
i_n	Input-Referred Current Noise	$f = 1\text{kHz}$		0.082		$\frac{\text{pA}}{\sqrt{\text{Hz}}}$
THD	Total Harmonic Distortion	$f = 1\text{kHz}$, $A_V = +1$ $R_L = 600\Omega$, $V_{\text{IN}} = 1V_{\text{PP}}$		0.022		%
	Amp-to-Amp Isolation	(Note 9)		123		dB

5V DC Electrical Characteristics

Unless otherwise specified, all limits guaranteed for $T_J = 25^\circ\text{C}$. $V^+ = 5\text{V}$, $V^- = 0\text{V}$, $V_{CM} = V^+/2$, $V_O = V^+/2$ and $R_L > 1\text{M}\Omega$. **Boldface** limits apply at the temperature extremes. See (Note 10)

Symbol	Parameter	Condition	Min (Note 6)	Typ (Note 5)	Max (Note 6)	Units	
V_{OS}	Input Offset Voltage	LMV931 (Single)		1	4 6	mV	
		LMV932 (Dual) LMV934 (Quad)		1	5.5 7.5	mV	
TCV_{OS}	Input Offset Voltage Average Drift			5.5		$\mu\text{V}/^\circ\text{C}$	
I_B	Input Bias Current			14	35 50	nA	
I_{OS}	Input Offset Current			9	25 40	nA	
I_S	Supply Current (per channel)			116	210 230	μA	
CMRR	Common Mode Rejection Ratio	$0 \leq V_{CM} \leq 3.8\text{V}$	60	86		dB	
		$4.6\text{V} \leq V_{CM} \leq 5.0\text{V}$ (Note 8)	55				
		$-0.2\text{V} \leq V_{CM} \leq 0\text{V}$	50	78			
		$5.0\text{V} \leq V_{CM} \leq 5.2\text{V}$					
PSRR	Power Supply Rejection Ratio	$1.8\text{V} \leq V^+ \leq 5\text{V}$ $V_{CM} = 0.5\text{V}$	75 70	100		dB	
CMVR	Input Common-Mode Voltage Range	For CMRR Range $\geq 50\text{dB}$	$T_A = 25^\circ\text{C}$	$V^- - 0.2$	-0.2 to 5.3	$V^+ + 0.2$	V
			$T_A = -40^\circ\text{C}$ to 85°C	V^-		V^+	
			$T_A = 125^\circ\text{C}$	$V^- + 0.3$		$V^+ - 0.3$	
A_V	Large Signal Voltage Gain LMV931 (Single)	$R_L = 600\Omega$ to 2.5V , $V_O = 0.2\text{V}$ to 4.8V	88 87	102		dB	
		$R_L = 2\text{k}\Omega$ to 2.5V , $V_O = 0.2\text{V}$ to 4.8V	94 93	113			
	Large Signal Voltage Gain LMV932 (Dual) LMV934 (Quad)	$R_L = 600\Omega$ to 2.5V , $V_O = 0.2\text{V}$ to 4.8V	81 78	90		dB	
		$R_L = 2\text{k}\Omega$ to 2.5V , $V_O = 0.2\text{V}$ to 4.8V	85 82	100			
V_O	Output Swing	$R_L = 600\Omega$ to 2.5V $V_{IN} = \pm 100\text{mV}$	4.855 4.835	4.890		V	
					0.120		0.160 0.180
		$R_L = 2\text{k}\Omega$ to 2.5V $V_{IN} = \pm 100\text{mV}$	4.945 4.935	4.967			
				0.037	0.065 0.075		
I_O	Output Short Circuit Current	LMV931, Sourcing, $V_O = 0\text{V}$ $V_{IN} = 100\text{mV}$	80 68	100		mA	
		Sinking, $V_O = 5\text{V}$ $V_{IN} = -100\text{mV}$	58 45	65			

5V AC Electrical Characteristics

Unless otherwise specified, all limits guaranteed for $T_J = 25^\circ\text{C}$. $V^+ = 5\text{V}$, $V^- = 0\text{V}$, $V_{\text{CM}} = V^+/2$, $V_O = 2.5\text{V}$ and $R_L > 1\text{M}\Omega$.

Boldface limits apply at the temperature extremes. See (Note 10)

Symbol	Parameter	Conditions	Min (Note 6)	Typ (Note 5)	Max (Note 6)	Units
SR	Slew Rate	(Note 7)		0.42		V/ μs
GBW	Gain-Bandwidth Product			1.5		MHz
Φ_m	Phase Margin			71		deg
G_m	Gain Margin			8		dB
e_n	Input-Referred Voltage Noise	$f = 1\text{kHz}$, $V_{\text{CM}} = 1\text{V}$		50		$\frac{\text{nV}}{\sqrt{\text{Hz}}}$
i_n	Input-Referred Current Noise	$f = 1\text{kHz}$		0.07		$\frac{\text{pA}}{\sqrt{\text{Hz}}}$
THD	Total Harmonic Distortion	$f = 1\text{kHz}$, $A_V = +1$ $R_L = 600\Omega$, $V_O = 1\text{V}_{\text{PP}}$		0.022		%
	Amp-to-Amp Isolation	(Note 9)		123		dB

Note 1: Absolute Maximum Ratings indicate limits beyond which damage to the device may occur. Operating Ratings indicate conditions for which the device is intended to be functional, but specific performance is not guaranteed. For guaranteed specifications and the test conditions, see the Electrical Characteristics.

Note 2: Human Body Model, applicable std. MIL-STD-883, Method 3015.7. Machine Model, applicable std. JESD22-A115-A (ESD MM std. of JEDEC) Field-Induced Charge-Device Model, applicable std. JESD22-C101-C (ESD FICDM std. of JEDEC).

Note 3: Applies to both single-supply and split-supply operation. Continuous short circuit operation at elevated ambient temperature can result in exceeding the maximum allowed junction temperature of 150°C . Output currents in excess of 45mA over long term may adversely affect reliability.

Note 4: The maximum power dissipation is a function of $T_{\text{J(MAX)}}$, θ_{JA} . The maximum allowable power dissipation at any ambient temperature is $P_D = (T_{\text{J(MAX)}} - T_A) / \theta_{\text{JA}}$. All numbers apply for packages soldered directly onto a PC Board.

Note 5: Typical values represent the most likely parametric norm as determined at the time of characterization. Actual typical values may vary over time and will also depend on the application and configuration. The typical values are not tested and are not guaranteed on shipped production material.

Note 6: All limits are guaranteed by testing or statistical analysis.

Note 7: Connected as voltage follower with input step from V^- to V^+ . Number specified is the slower of the positive and negative slew rates.

Note 8: For guaranteed temperature ranges, see Input Common-Mode Voltage Range specifications.

Note 9: Input referred, $R_L = 100\text{k}\Omega$ connected to $V^+/2$. Each amp excited in turn with 1kHz to produce $V_O = 3V_{\text{PP}}$ (For Supply Voltages $< 3\text{V}$, $V_O = V^+$).

Note 10: Electrical Table values apply only for factory testing conditions at the temperature indicated. Factory testing conditions result in very limited self-heating of the device such that $T_J = T_A$. No guarantee of parametric performance is indicated in the electrical tables under conditions of internal self-heating where $T_J > T_A$. See Applications section for information of temperature derating of the device. Absolute Maximum Ratings indicated junction temperature limits beyond which the device may be permanently degraded, either mechanically or electrically.

Connection Diagrams

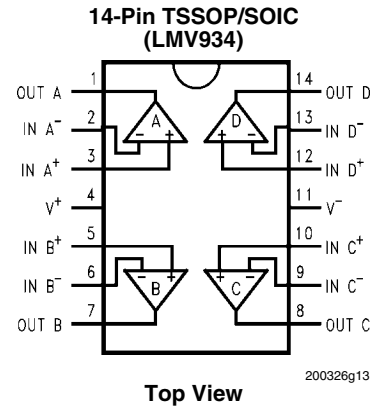
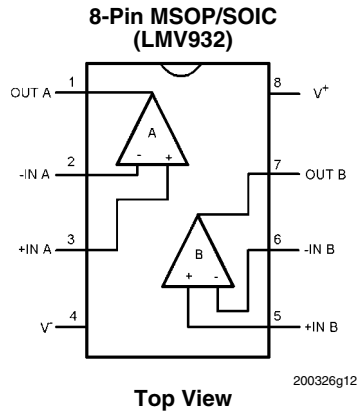
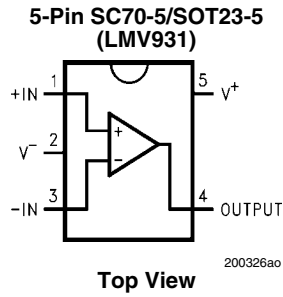

Ordering Information

Package	Part Number	Packaging Marking	Transport Media	NSC Drawing
5-Pin SC70	LMV931MG	A74	1k Units Tape and Reel	MAA05A
	LMV931MGX		3k Units Tape and Reel	
5-Pin SOT23	LMV931MF	A79A	1k Units Tape and Reel	MF05A
	LMV931MFX		3k Units Tape and Reel	
8-Pin MSOP	LMV932MM	A86A	1k Units Tape and Reel	MUA08A
	LMV932MMX		3.5k Units Tape and Reel	
8-Pin SOIC	LMV932MA	LMV932MA	Rails	M08A
	LMV932MAX		2.5k Units Tape and Reel	
14-Pin TSSOP	LMV934MT	LMV934MT	Rails	MTC14
	LMV934MTX		2.5k Units Tape and Reel	
14-Pin SOIC	LMV934MA	LMV934MA	Rails	M14A
	LMV934MAX		2.5k Units Tape and Reel	

Typical Performance Characteristics

Unless otherwise specified, $V_S = +5V$, single supply, $T_A = 25^\circ C$.

Supply Current vs. Supply Voltage (LMV931)

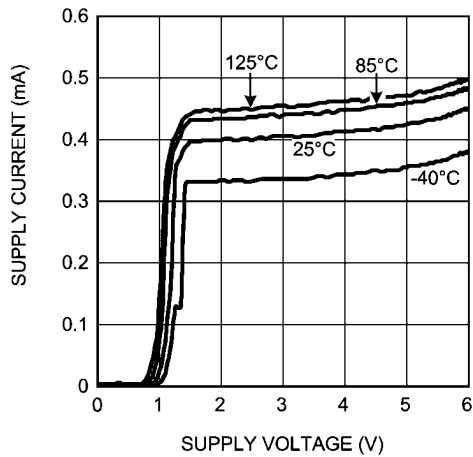

20032623

Sourcing Current vs. Output Voltage

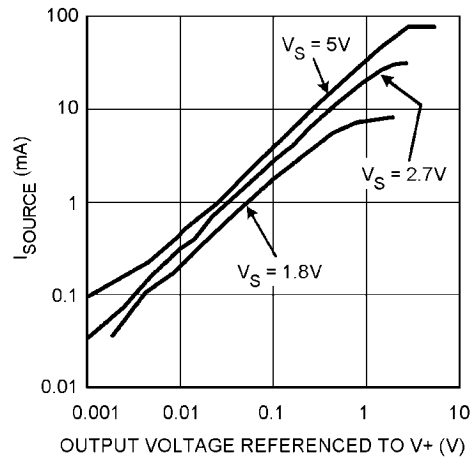

20032625

Sinking Current vs. Output Voltage

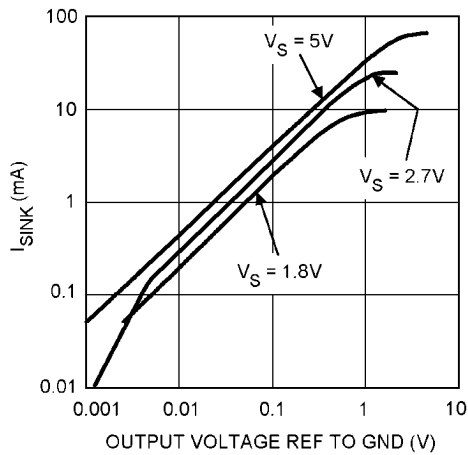

20032628

Output Voltage Swing vs. Supply Voltage

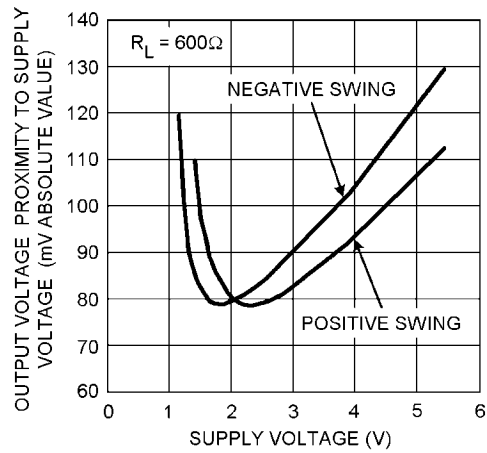

20032649

Output Voltage Swing vs. Supply Voltage

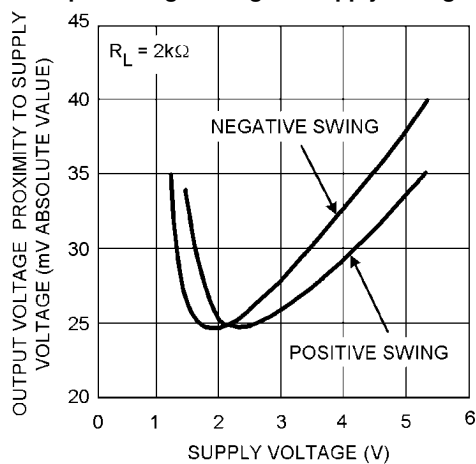

20032650

Gain and Phase vs. Frequency

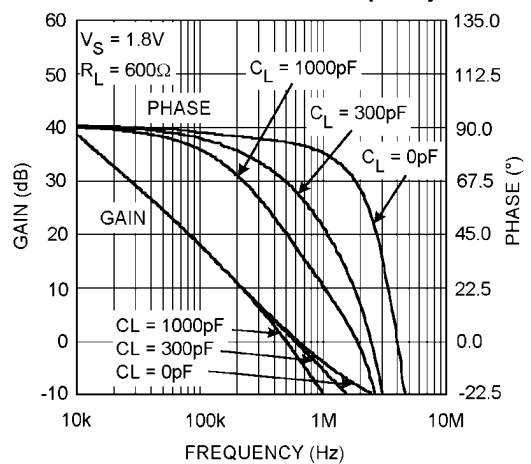

20032698

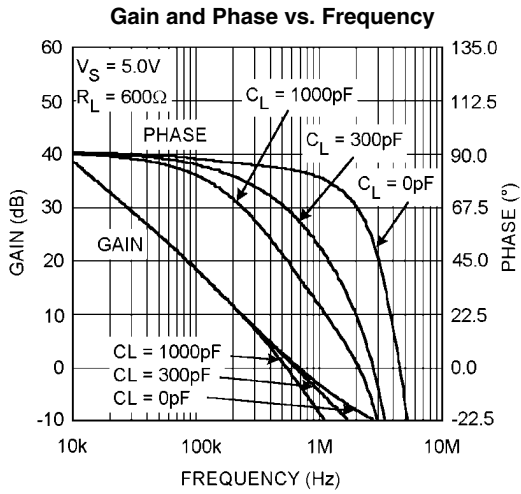

200326g9

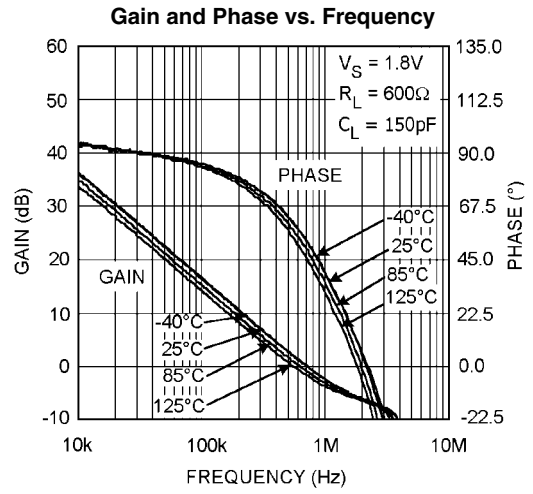

200326g10

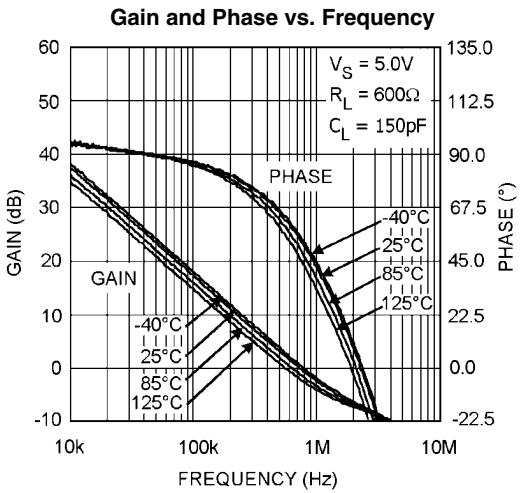

200326g11

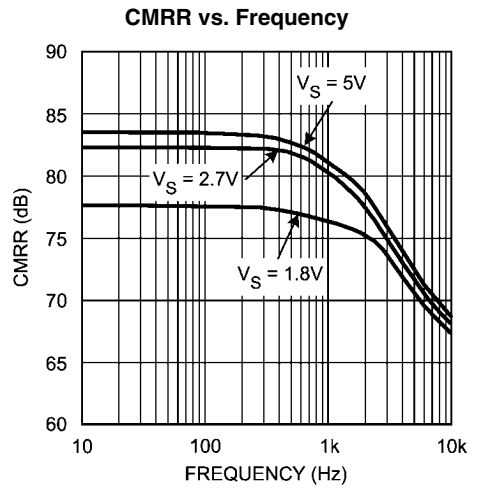

20032639

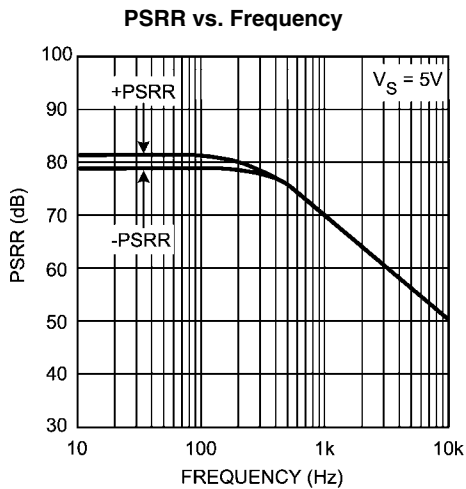

20032656

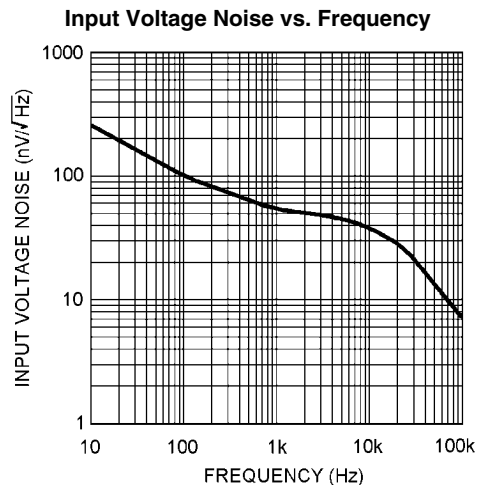

20032658

Input Current Noise vs. Frequency

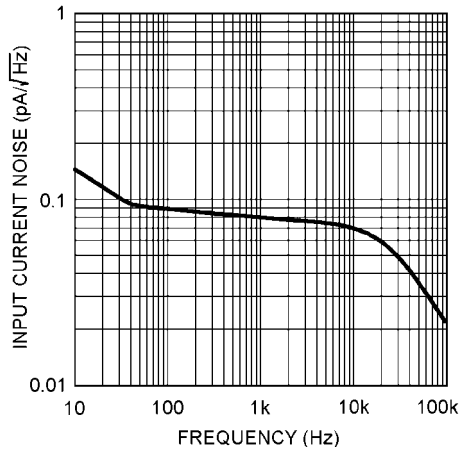

20032666

THD vs. Frequency

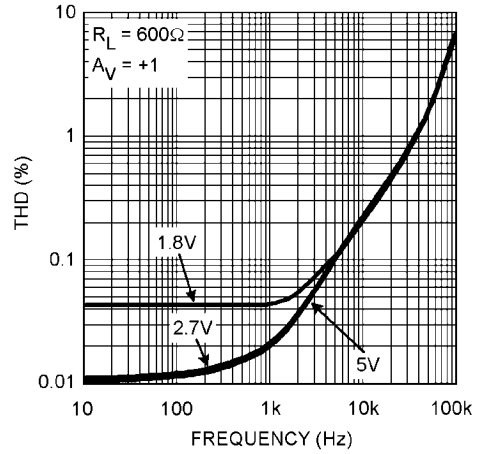

20032667

THD vs. Frequency

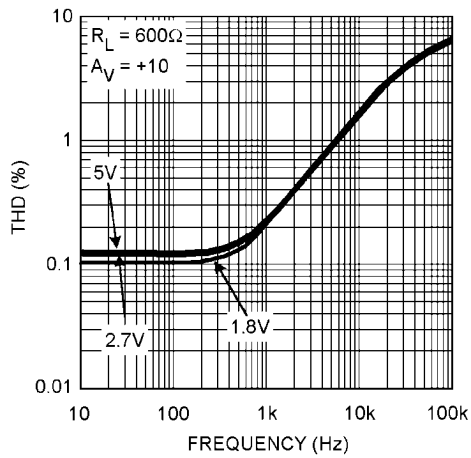

20032668

Slew Rate vs. Supply Voltage

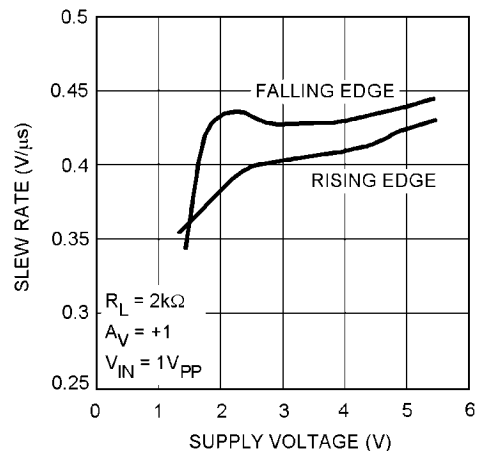

20032669

Small Signal Non-Inverting Response

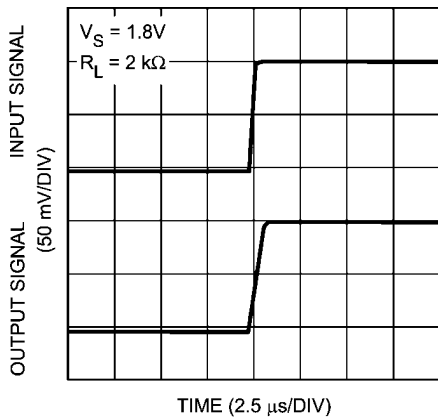

20032670

Small Signal Non-Inverting Response

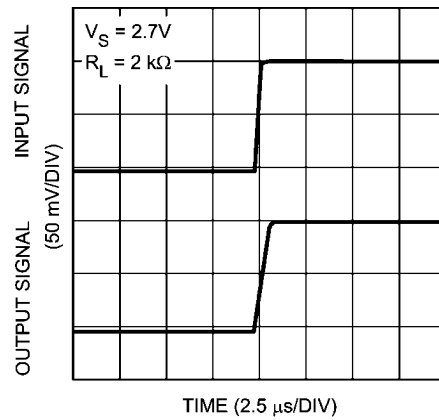

20032671

Small Signal Non-Inverting Response

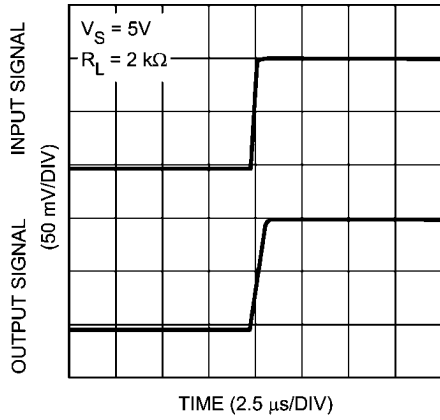

20032672

Large Signal Non-Inverting Response

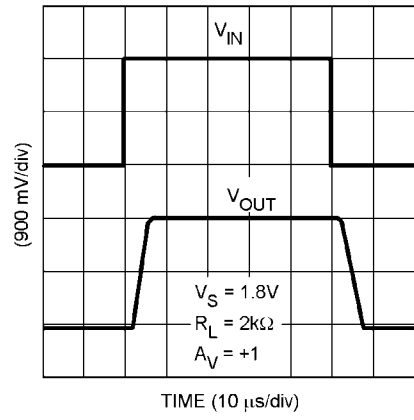

20032673

Large Signal Non-Inverting Response

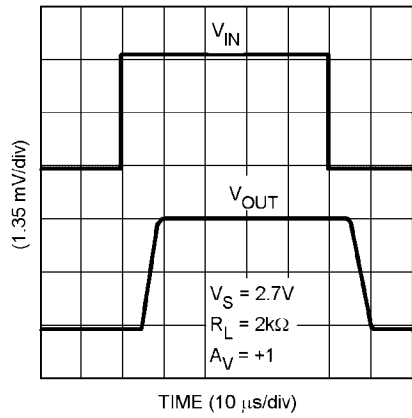

20032674

Large Signal Non-Inverting Response

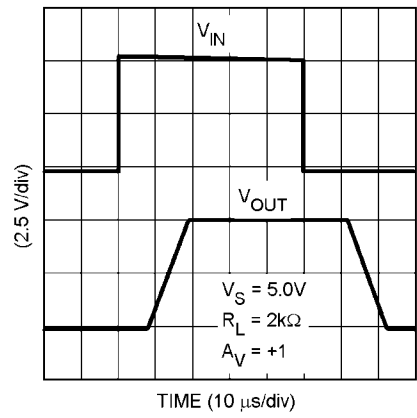

20032675

Short Circuit Current vs. Temperature (Sinking)

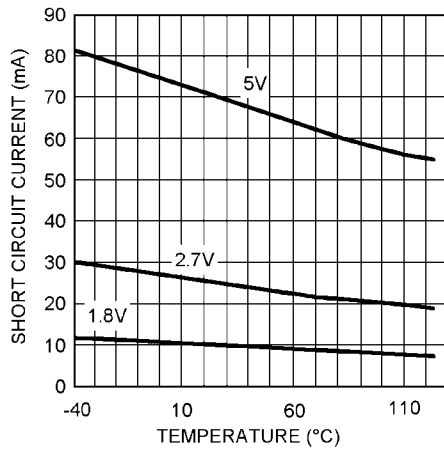

20032676

Short Circuit Current vs. Temperature (Sourcing)

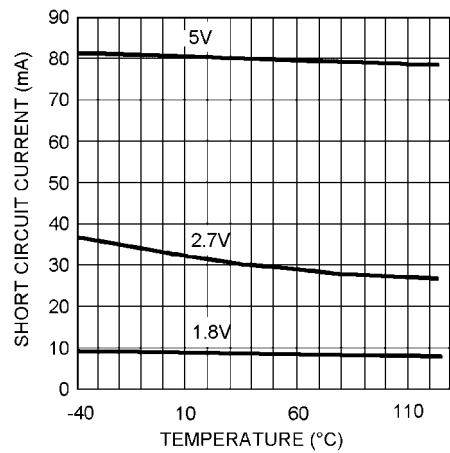

20032677

Offset Voltage vs. Common Mode Range

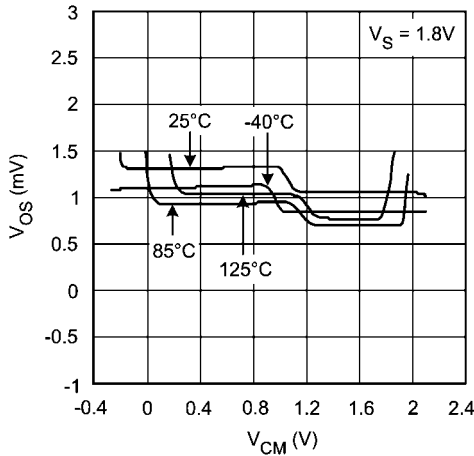

20032636

Offset Voltage vs. Common Mode Range

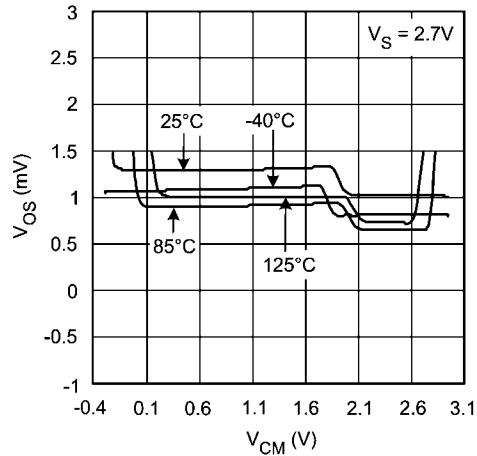

20032637

Offset Voltage vs. Common Mode Range

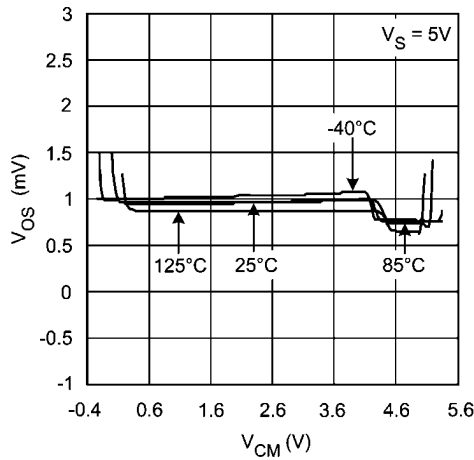

20032638

Application Note

INPUT AND OUTPUT STAGE

The rail-to-rail input stage of this family provides more flexibility for the designer. The LMV931/LMV932/LMV934 use a complimentary PNP and NPN input stage in which the PNP stage senses common mode voltage near V^- and the NPN stage senses common mode voltage near V^+ . The transition from the PNP stage to NPN stage occurs 1V below V^+ . Since both input stages have their own offset voltage, the offset of the amplifier becomes a function of the input common mode voltage and has a crossover point at 1V below V^+ .

This V_{OS} crossover point can create problems for both DC and AC coupled signals if proper care is not taken. Large input signals that include the V_{OS} crossover point will cause distortion in the output signal. One way to avoid such distortion is to keep the signal away from the crossover. For example, in a unity gain buffer configuration and with $V_S = 5V$, a 5V peak-to-peak signal will contain input-crossover distortion while a 3V peak-to-peak signal centered at 1.5V will not contain input-crossover distortion as it avoids the crossover point. Another way to avoid large signal distortion is to use a gain of -1 circuit which avoids any voltage excursions at the input terminals of the amplifier. In that circuit, the common mode DC voltage can be set at a level away from the V_{OS} cross-over point. For small signals, this transition in V_{OS} shows up as a V_{CM} de-

pendent spurious signal in series with the input signal and can effectively degrade small signal parameters such as gain and common mode rejection ratio. To resolve this problem, the small signal should be placed such that it avoids the V_{OS} crossover point. In addition to the rail-to-rail performance, the output stage can provide enough output current to drive 600Ω loads. Because of the high current capability, care should be taken not to exceed the $150^\circ C$ maximum junction temperature specification.

INPUT BIAS CURRENT CONSIDERATION

The LMV931/LMV932/LMV934 family has a complementary bipolar input stage. The typical input bias current (I_B) is 15nA. The input bias current can develop a significant offset voltage. This offset is primarily due to I_B flowing through the negative feedback resistor, R_F . For example, if I_B is 50nA and R_F is $100k\Omega$, then an offset voltage of 5mV will develop ($V_{OS} = I_B \times R_F$). Using a compensation resistor (R_C), as shown in Figure 1, cancels this effect. But the input offset current (I_{OS}) will still contribute to an offset voltage in the same manner.

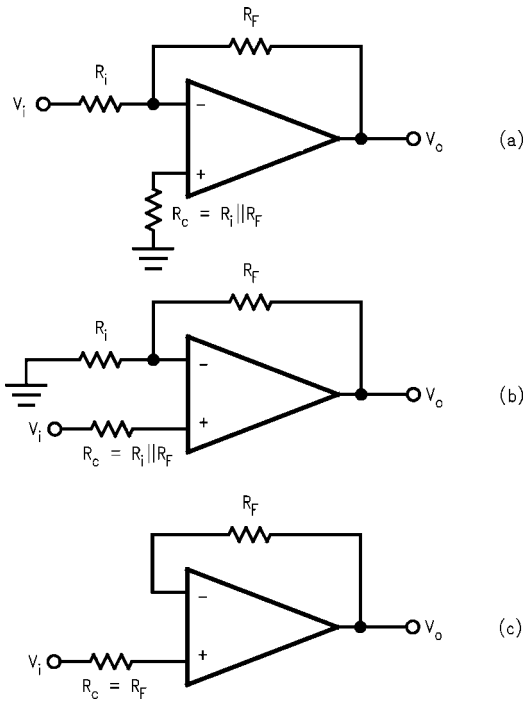

20032659

FIGURE 1. Canceling the Offset Voltage due to Input Bias Current

Typical Applications

HIGH SIDE CURRENT SENSING

The high side current sensing circuit (*Figure 2*) is commonly used in a battery charger to monitor charging current to prevent over charging. A sense resistor R_{SENSE} is connected to the battery directly. This system requires an op amp with rail-to-rail input. The LMV931/LMV932/LMV934 are ideal for this application because its common mode input range goes up to the rail.

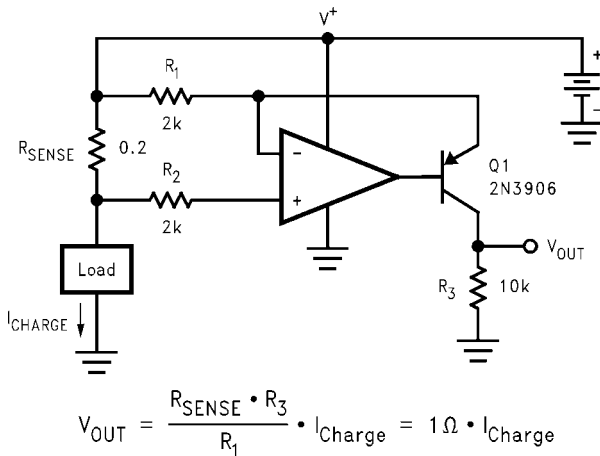

200326h0

FIGURE 2. High Side Current Sensing

HALF-WAVE RECTIFIER WITH RAIL-TO-GROUND OUTPUT SWING

Since the LMV931/LMV932/LMV934 input common mode range includes both positive and negative supply rails and the output can also swing to either supply, achieving half-wave rectifier functions in either direction is an easy task. All that is needed are two external resistors; there is no need for diodes or matched resistors. The half wave rectifier can have either positive or negative going outputs, depending on the way the circuit is arranged.

In *Figure 3* the circuit is referenced to ground, while in *Figure 4* the circuit is biased to the positive supply. These configurations implement the half wave rectifier since the LMV931/LMV932/LMV934 can not respond to one-half of the incoming waveform. It can not respond to one-half of the incoming because the amplifier can not swing the output beyond either rail therefore the output disengages during this half cycle. During the other half cycle, however, the amplifier achieves a half wave that can have a peak equal to the total supply voltage. R_1 should be large enough not to load the LMV931/LMV932/LMV934.

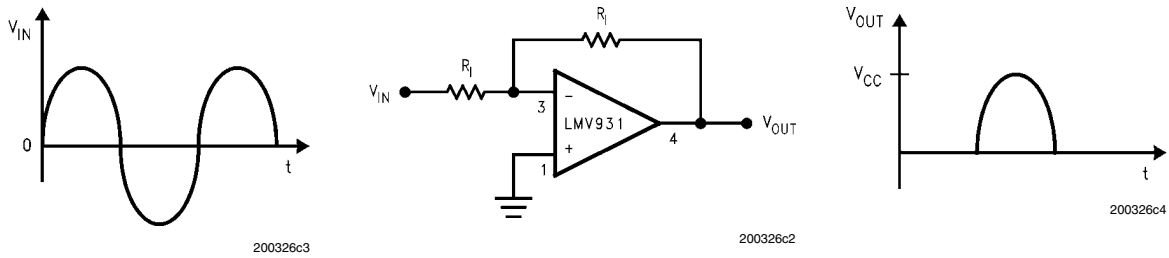

FIGURE 3. Half-Wave Rectifier with Rail-To-Ground Output Swing Referenced to Ground

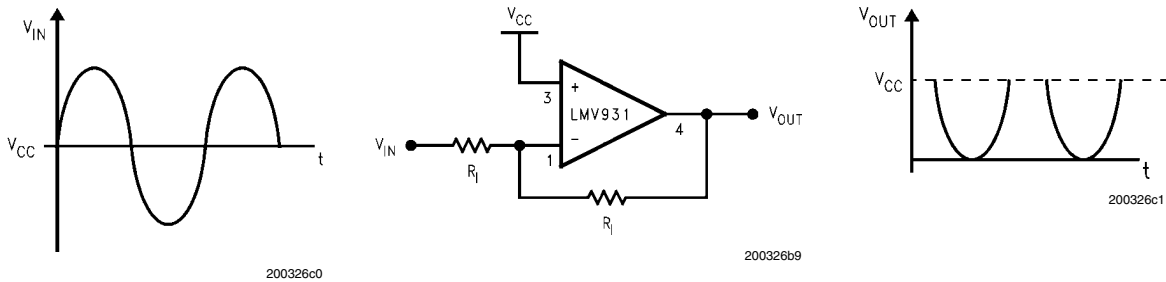

FIGURE 4. Half-Wave Rectifier with Negative-Going Output Referenced to V_{CC}

INSTRUMENTATION AMPLIFIER WITH RAIL-TO-RAIL INPUT AND OUTPUT

Some manufactures make a non-“rail-to-rail”-op amp rail-to-rail by using a resistive divider on the inputs. The resistors divide the input voltage to get a rail-to-rail input range. The problem with this method is that it also divides the signal, so in order to get the obtained gain, the amplifier must have a higher closed loop gain. This raises the noise and drift by the internal gain factor and lowers the input impedance. Any mismatch in these precision resistors reduces the CMRR as well. The LMV931/LMV932/LMV934 is rail-to-rail and therefore doesn't have these disadvantages.

Using three of the LMV931/LMV932/LMV934 amplifiers, an instrumentation amplifier with rail-to-rail inputs and outputs can be made as shown in *Figure 5*.

In this example, amplifiers on the left side act as buffers to the differential stage. These buffers assure that the input impedance is very high and require no precision matched resistors in the input stage. They also assure that the difference amp is driven from a voltage source. This is necessary to maintain the CMRR set by the matching R_1 - R_2 with R_3 - R_4 . The gain is set by the ratio of R_2/R_1 and R_3 should equal R_4 and R_4 equal R_2 . With both rail-to-rail input and output ranges,

the input and output are only limited by the supply voltages. Remember that even with rail-to-rail outputs, the output can not swing past the supplies so the combined common mode voltages plus the signal should not be greater than the supplies or limiting will occur. For additional applications, see National Semiconductor application notes AN-29, AN-31, AN-71, and AN-127.

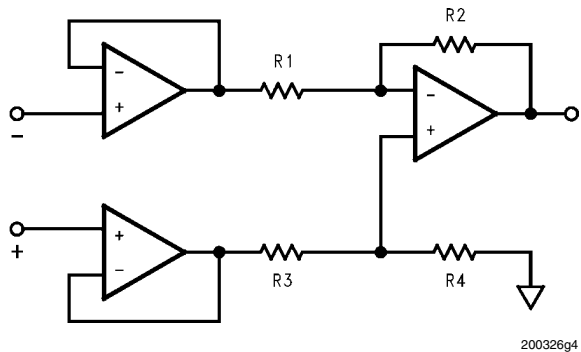
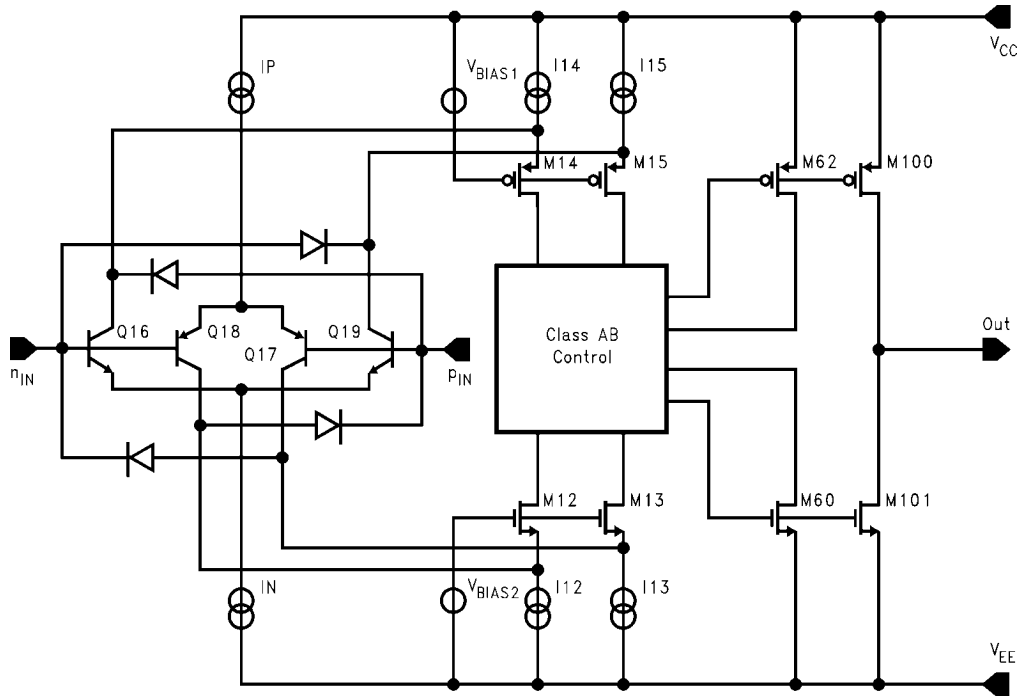

FIGURE 5. Rail-to-rail Instrumentation Amplifier

Simplified Schematic



200326a9

Physical Dimensions inches (millimeters) unless otherwise noted

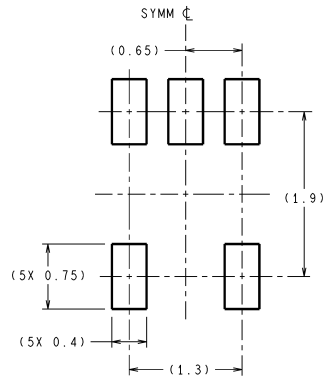
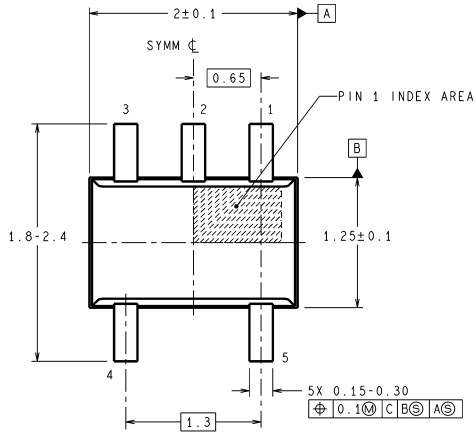

LAND PATTERN RECOMMENDATION

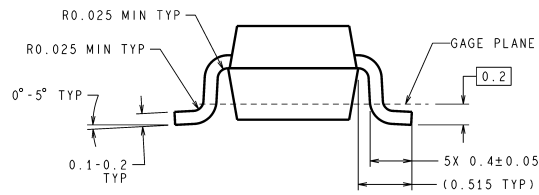
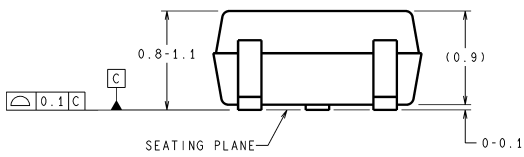

DIMENSIONS ARE IN MILLIMETERS
DIMENSIONS IN () FOR REFERENCE ONLY

MAA05A (Rev D)

5-Pin SC70
NS Package Number MAA05A

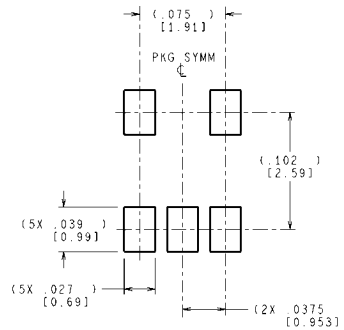
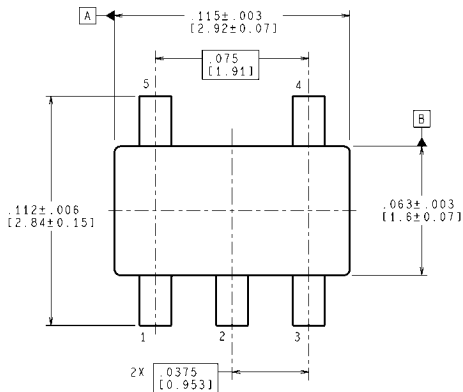

LAND PATTERN RECOMMENDATION

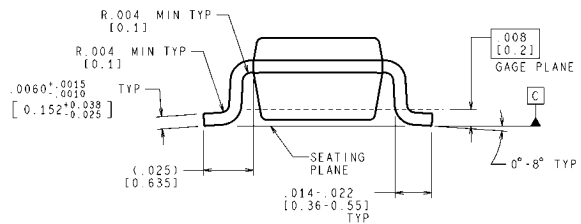
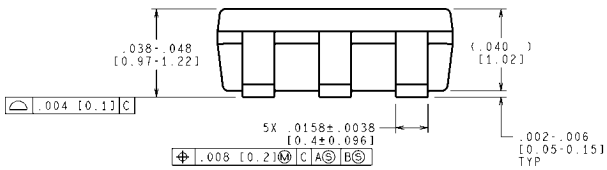

CONTROLLING DIMENSION IS INCH
VALUES IN [] ARE MILLIMETERS
DIMENSIONS IN () FOR REFERENCE ONLY

MF05A (Rev C)

5-Pin SOT23
NS Package Number MF05A

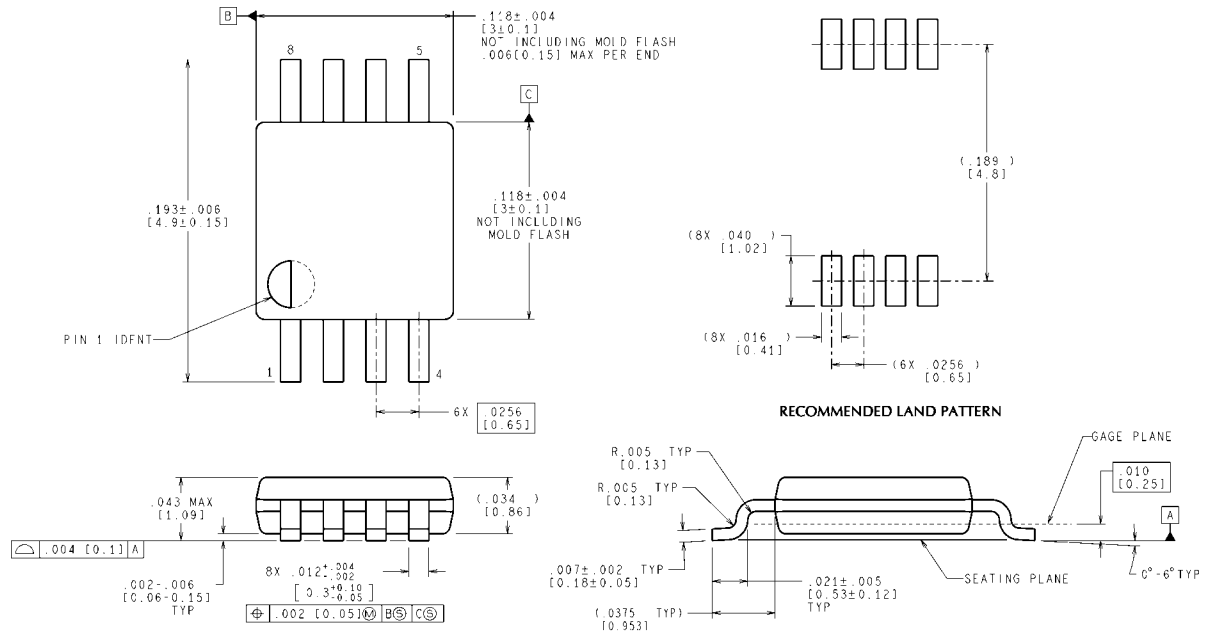

CONTROLLING DIMENSION IS INCH
VALUES IN [] ARE MILLIMETERS

MUA08A (Rev F)

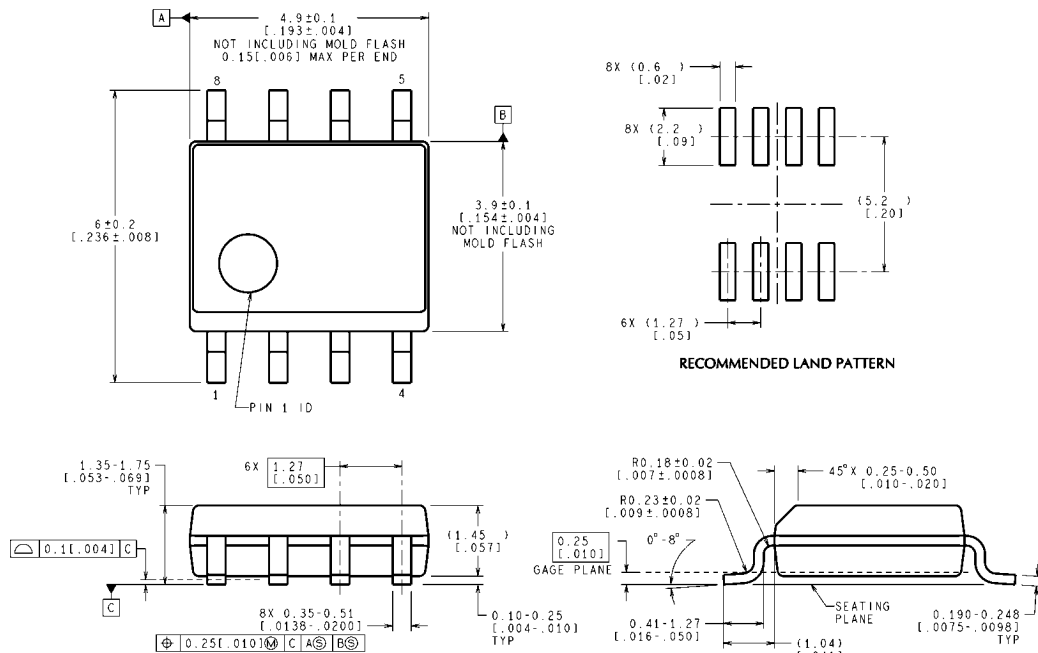

CONTROLLING DIMENSION IS MILLIMETER
VALUES IN [] ARE INCHES
DIMENSIONS IN () FOR REFERENCE ONLY

M08A (Rev L)

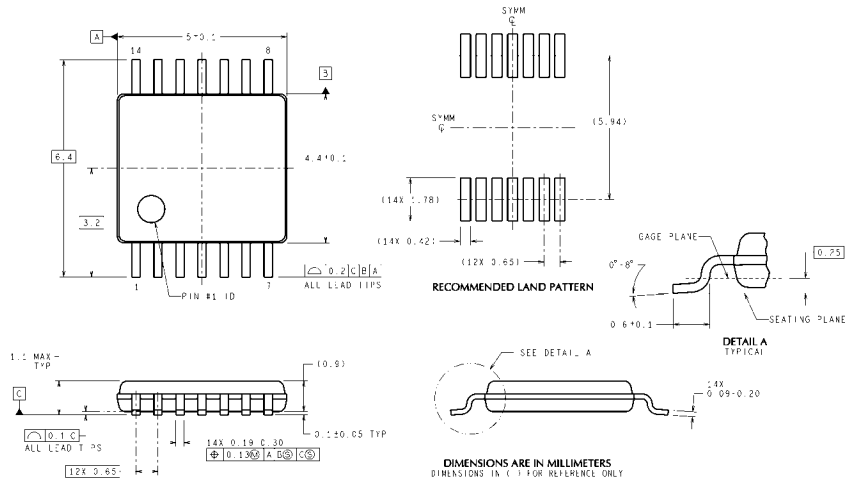

14-Pin TSSOP
NS Package Number MTC14

MTC14 (Rev D)

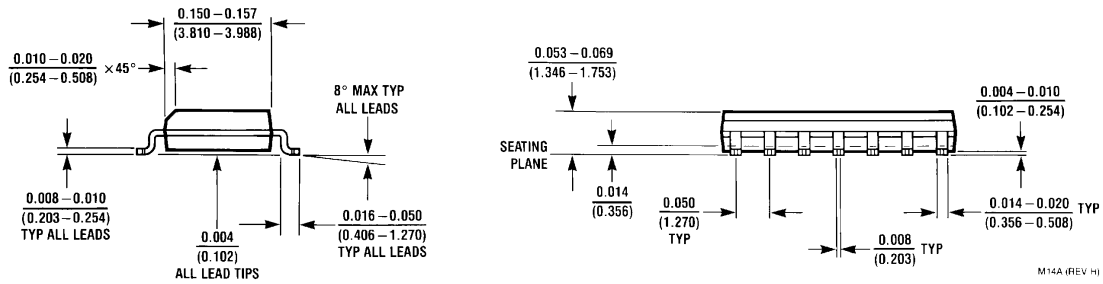
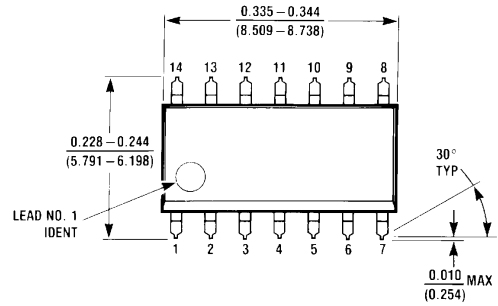

14-Pin SOIC
NS Package Number M14A

M14A (REV H)

Notes

For more National Semiconductor product information and proven design tools, visit the following Web sites at:

Products		Design Support	
Amplifiers	www.national.com/amplifiers	WEBENCH	www.national.com/webench
Audio	www.national.com/audio	Analog University	www.national.com/AU
Clock Conditioners	www.national.com/timing	App Notes	www.national.com/appnotes
Data Converters	www.national.com/adc	Distributors	www.national.com/contacts
Displays	www.national.com/displays	Green Compliance	www.national.com/quality/green
Ethernet	www.national.com/ethernet	Packaging	www.national.com/packaging
Interface	www.national.com/interface	Quality and Reliability	www.national.com/quality
LVDS	www.national.com/lvds	Reference Designs	www.national.com/refdesigns
Power Management	www.national.com/power	Feedback	www.national.com/feedback
Switching Regulators	www.national.com/switchers		
LDOs	www.national.com/ldo		
LED Lighting	www.national.com/led		
PowerWise	www.national.com/powerwise		
Serial Digital Interface (SDI)	www.national.com/sdi		
Temperature Sensors	www.national.com/tempsensors		
Wireless (PLL/VCO)	www.national.com/wireless		

THE CONTENTS OF THIS DOCUMENT ARE PROVIDED IN CONNECTION WITH NATIONAL SEMICONDUCTOR CORPORATION ("NATIONAL") PRODUCTS. NATIONAL MAKES NO REPRESENTATIONS OR WARRANTIES WITH RESPECT TO THE ACCURACY OR COMPLETENESS OF THE CONTENTS OF THIS PUBLICATION AND RESERVES THE RIGHT TO MAKE CHANGES TO SPECIFICATIONS AND PRODUCT DESCRIPTIONS AT ANY TIME WITHOUT NOTICE. NO LICENSE, WHETHER EXPRESS, IMPLIED, ARISING BY ESTOPPEL OR OTHERWISE, TO ANY INTELLECTUAL PROPERTY RIGHTS IS GRANTED BY THIS DOCUMENT.

TESTING AND OTHER QUALITY CONTROLS ARE USED TO THE EXTENT NATIONAL DEEMS NECESSARY TO SUPPORT NATIONAL'S PRODUCT WARRANTY. EXCEPT WHERE MANDATED BY GOVERNMENT REQUIREMENTS, TESTING OF ALL PARAMETERS OF EACH PRODUCT IS NOT NECESSARILY PERFORMED. NATIONAL ASSUMES NO LIABILITY FOR APPLICATIONS ASSISTANCE OR BUYER PRODUCT DESIGN. BUYERS ARE RESPONSIBLE FOR THEIR PRODUCTS AND APPLICATIONS USING NATIONAL COMPONENTS. PRIOR TO USING OR DISTRIBUTING ANY PRODUCTS THAT INCLUDE NATIONAL COMPONENTS, BUYERS SHOULD PROVIDE ADEQUATE DESIGN, TESTING AND OPERATING SAFEGUARDS.

EXCEPT AS PROVIDED IN NATIONAL'S TERMS AND CONDITIONS OF SALE FOR SUCH PRODUCTS, NATIONAL ASSUMES NO LIABILITY WHATSOEVER, AND NATIONAL DISCLAIMS ANY EXPRESS OR IMPLIED WARRANTY RELATING TO THE SALE AND/OR USE OF NATIONAL PRODUCTS INCLUDING LIABILITY OR WARRANTIES RELATING TO FITNESS FOR A PARTICULAR PURPOSE, MERCHANTABILITY, OR INFRINGEMENT OF ANY PATENT, COPYRIGHT OR OTHER INTELLECTUAL PROPERTY RIGHT.

LIFE SUPPORT POLICY

NATIONAL'S PRODUCTS ARE NOT AUTHORIZED FOR USE AS CRITICAL COMPONENTS IN LIFE SUPPORT DEVICES OR SYSTEMS WITHOUT THE EXPRESS PRIOR WRITTEN APPROVAL OF THE CHIEF EXECUTIVE OFFICER AND GENERAL COUNSEL OF NATIONAL SEMICONDUCTOR CORPORATION. As used herein:

Life support devices or systems are devices which (a) are intended for surgical implant into the body, or (b) support or sustain life and whose failure to perform when properly used in accordance with instructions for use provided in the labeling can be reasonably expected to result in a significant injury to the user. A critical component is any component in a life support device or system whose failure to perform can be reasonably expected to cause the failure of the life support device or system or to affect its safety or effectiveness.

National Semiconductor and the National Semiconductor logo are registered trademarks of National Semiconductor Corporation. All other brand or product names may be trademarks or registered trademarks of their respective holders.

Copyright© 2008 National Semiconductor Corporation

For the most current product information visit us at www.national.com



National Semiconductor Americas Technical Support Center
 Email: support@nsc.com
 Tel: 1-800-272-9959

National Semiconductor Europe Technical Support Center
 Email: europe.support@nsc.com
 German Tel: +49 (0) 180 5010 771
 English Tel: +44 (0) 870 850 4288

National Semiconductor Asia Pacific Technical Support Center
 Email: ap.support@nsc.com

National Semiconductor Japan Technical Support Center
 Email: jpn.feedback@nsc.com